



# DENON

## Double CD/MP3 Player DN-D4000



### MP3 Playback

- Supports V.B.R & C.B.R
- Folder/File search
- ID3-Tag display (Artist, Album & Title)
- Play List Compatible (.m3u form)

### CD-R/RW Disc Playback

The DN-D4000 plays finalized CD-R/RW discs.

### CD TEXT display

Artist and track names can be displayed for discs that contain CD TEXT information. Most popular CD-R/RW burning software programs give you the ability to add CD TEXT.

### 2 Seamless Loops (per drive)

By using the start points (A-1 or A-2) you can easily create two seamless loops by jumping from one point (A1) to another (A2). The two loops can be set anywhere within the same disc.

### 2 Hot Starts & Stutter Cue Points (per drive)

Hot Start playback gives you the power of controlling two different CUE points 'on the fly' and seamlessly. Excellent for slam-mixing from one track to another and for 'same track' real-time remixing. In Stutter mode, the same two CUE points are utilized for 'cue point sampling'. Momentary audio can be started instantly when either 'A' button is pressed and held down. If this is done repeatedly, a stutter sound of a vocal or beat is simply achieved

### Memo functions

- Track memo (300 tracks memo per drive)  
Cue point, Playback Pitch, Pitch Range and Seamless Loop A and B data can be stored in memory.
- Disc memo (10 discs memo per drive)  
The disc memo function further allows MP3 disc to start as quick as CD without reading MP3 disc information.

### Shock Proof Memory (Audio CD: 10 sec., MP3: 100 sec.)

This guards against audible interruptions due to external mechanical shocks such as bumps or other hard vibrations, which is especially helpful for the mobile DJ as well as for nightclub-installed applications.

### Brake Effect

In Brake mode, the playing speed comes to a quick halt, simulating the STOP function on a DJ turntable.

### Pitch Bend ( $\pm 18\%$ )

Pitch bend provides momentary pitch change in order to fine tune your beats while beat mixing.

### Jog Bend

Extreme playback speeds can be changed by using the inner Jog wheel. The maximum range of change is  $-35\%$  to  $+50\%$ .

### Pitch Control ( $\pm 4.0\%$ , $\pm 10.0\%$ or $\pm 16.0\%$ )

### Instant Start

### Playback mode selection button (SINGLE/CONT)

### Rotary Track Select Knob

Tracks can be selected by turning the knob 360 degrees in either direction. By pressing the knob and turning it at the same time, you can increment 10 tracks at a time.

### Fader Start

This function provides playback control of our CD drives via the cross fader on a compatible fader start mixer. Up to 4 different CUE points can be controlled instantly and seamlessly just by using the cross fader.

### E.O.M. (end of track alert)

### Sleep function

Auto protects the CD mechanism for longevity. This function will automatically shut down the drives after a period of inactivity and prolong the useful life of the internal parts. Similar to a screen saver on a computer.

### Digital Outputs: SPDIF

The digital outputs are used for direct digital dubbing to a digital recorder, such as a MiniDisc, DAT or CD-R device. It can also be used for direct connection to an outboard digital processor or mixing console.

## FL tube displays with Dot Matrix text characters

### Disc Tray LED

This bright L.E.D. provides illumination over the disc trays when the drawers are opened, also giving a visual warning to protect the trays from accidental damage in low light environments.

### Bar Segment Display

A 10-segment track time display shows at-a-glance the current playback position within the playing track.

### Program Play

With Program play, up to 25 tracks on a disc can be programmed for playback, and the programs for up to 6 discs (3 discs per drive) can be stored in memory.

### Power On Play

With 2 discs loaded, continuous unattended playback is possible. Great for restaurants, bars and nightclubs at opening time.

### Repeat Play (Track Repeat, Disc Repeat)

Single Repeat and Continuous Repeat playback are possible.

### Relay Playback

Sets the machine to 'auto pilot' and plays tracks from drive to drive automatically. Great for the cocktail hour or dinner time when the DJ needs to take a brake.

### Jog / Shuttle Wheel (50 mm)

### Firmware Upgradable by CD-ROM Disc

### Illuminated Action Buttons with Tactile Feedback

### User Adjustable Presets

("\*" indicates the default setting.)

- Auto Cue: OFF/-48\*/-42/-36 dB
- Brake Time: 0.5/1.0/1.5/2.0\* sec.
- Relay Mode: ON/OFF\*
- E.O.M: OFF/10\*/15/20/30/60/90 sec.
- Auto Tray Close: OFF/10/30\*/60sec.
- Sleep Time: 10/20/30\* min.
- Digital Out: ON\*/OFF
- Fader Start: Cue and Play\*/Play, Pause
- Power On Play: ON/OFF\*
- MP3 Play List: ON/OFF\*
- Disc Memo: ON\*/OFF
- Play Mode: Single\*/Continuous
- Time Mode: Elapsed\*/Remain
- Pitch Range: ±4/10\*/16%
- Track Memo All Clear
- Disc Memo All Clear
- Program All Clear
- Version Display
- Preset Clear

## Specifications

Type	Double CD Player
Audio Channels	2 channels (Stereo)
Sampling Frequency	44.1 kHz (Normal Pitch)
Frequency Response	20 Hz - 20 kHz

### Analog outputs (1 kHz, 0 dB playback)

Transfer and connector	Unbalanced, RCA connector
Output level	2.0 Vrms, 10 kohm

### Digital output

Transfer and connector	Coaxial
Signal format	SPDIF

Power supply	AC120 V, 60 Hz
Power Consumption	20 W

### Dimensions

Player unit	482 (W) x 88 (H) x 252 (D) mm 19" (W) x 3.5" (H) x 9.9" (D)
Remote control unit	482 (W) x 88 (H) x 62 (D) mm 19" (W) x 3.5" (H) x 2.4" (D)

### Weight

Player unit	6.2 kg
Remote control unit	1.9 kg

### Standard Accessories

Pin connected cord	2 pairs
Remote connecting cable	1 pc

Design and specifications are subject to change without notice.

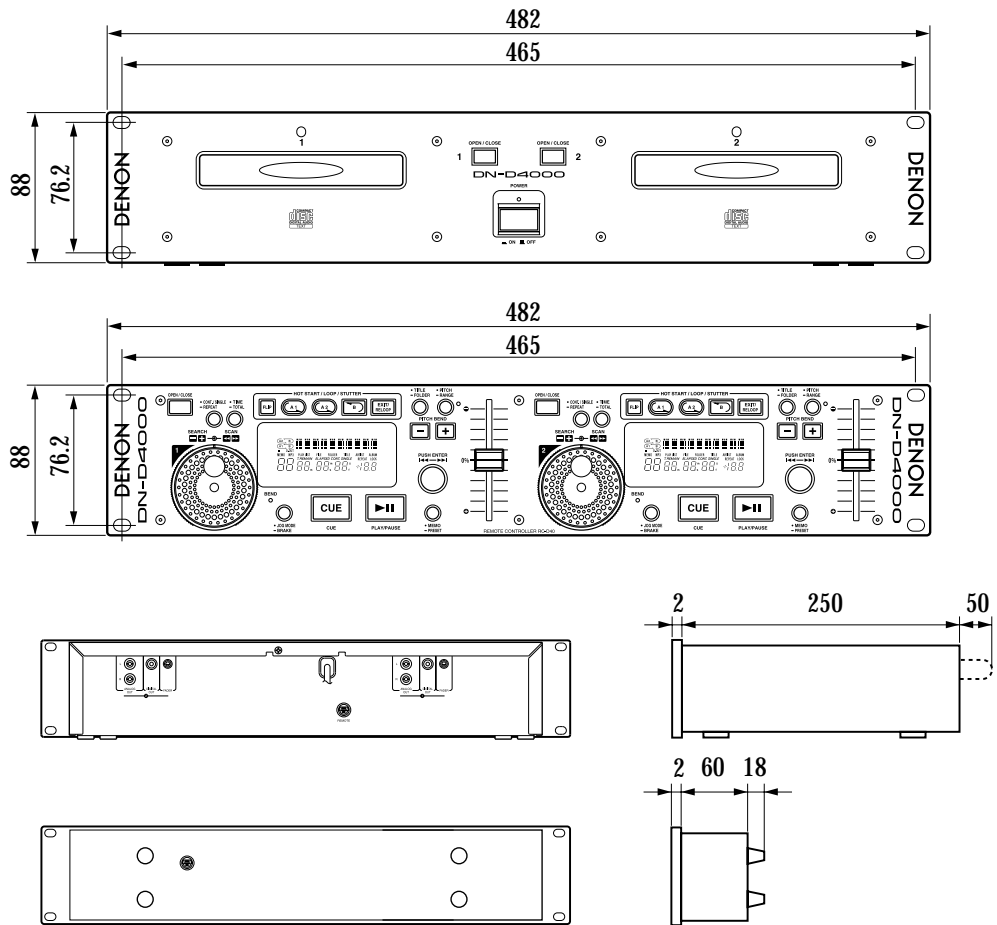

# DENON

DENON ELECTRONICS (USA) INC.  
19 CHAPIN ROAD, BUILDING C, PINE BROOK, NJ 07058-9777 USA  
TEL: 973-396-0810 www.usa.denon.com

DENON CANADA INC.  
505 APPLE CREEK BLVD. UNIT 5 MARKHAM, ONTARIO L3R 5B1 CANADA  
TEL: 905-475-4085 www.denon.ca

DENON, LTD.  
3-16-11, YUSHIMA, BUNKYO-KU, TOKYO 113-0034, JAPAN

XXXX0203 A